



Timbertop Slat Panel

FilaSorb™ 12

acoufelt
making quiet

Product Detail

Product	Timbertop Panel
Application	Wall and ceiling
Composition	Polyester + MDF + Non PVC finish
Material	FilaSorb™ & NAVURBAN™
Recycled content	60% min
Weight	4800g/m ² +/- 10%
Size	1200 x 2800mm Custom sizes available
Thickness	16mm +/- 10% 25mm +/- 10%

Guarantees

Warranty against defects	20 Years*
Light fastness warranty	20 Years*
	<small>*conditions apply</small>

Technical Data

Indoor Air Quality	SCS-EC10.3-2014 v4.0 meeting standard CDPH/EHLB Standard Method v.1.2-2017, ≤ 0.5mg/m ³	
Light Fastness	ISO 105-B02 1994, 6-7	
Fire Test Method	CORE	FACING
16mm	AS ISO 9705 – Group 1, SMOGRA – 7.6m ² /s ²	AS ISO 9705 – Group 3
25mm	AS ISO 9705 – Group 1, SMOGRA – 7.6m ² /s ²	AS ISO 9705 – Group 2

Sustainability

• Recognised under LEED

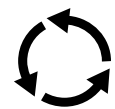

Made from 60% min.
recycled content



Declare Living Building
Challenge compliant

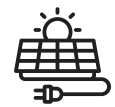

Generated using
40% solar energy



Recyclable at
end-of-life

Acoustic Performance

Sound Absorption ISO 354-2006
NRC 0.55 (no air gap)
NRC 0.65 (20mm air gap)

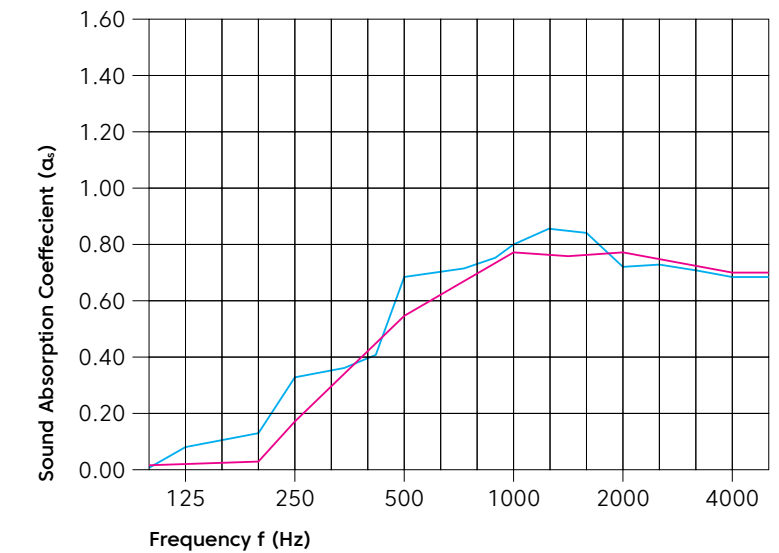

*Graph not to scale.

Frequency (Hz)	125	250	500	1000	2000	4000	NRC
12mm α _s	0.04	0.19	0.55	0.77	0.77	0.70	0.55
12mm α _s , 20mm air gap	0.07	0.34	0.69	0.80	0.73	0.68	0.65

Choose Your Finish

Select Woodgrain Finish



Albany Oak

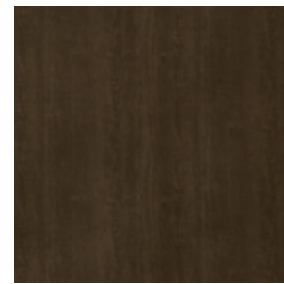

Ashgrove



Ashwood



Auchen Flower



Balmoral



Birch



Birchgrove



Blackheath



Bugendore



Byron Blackbutt

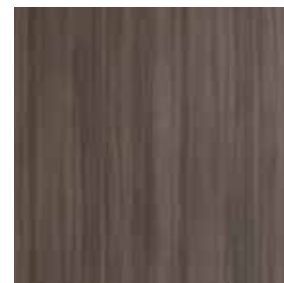

Clifton Hill

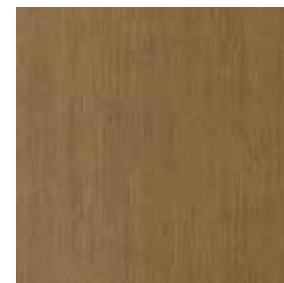

Coolum Spotted Gum



Daylesford



Earlwood

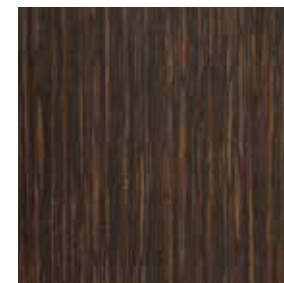

Eureka Ebony

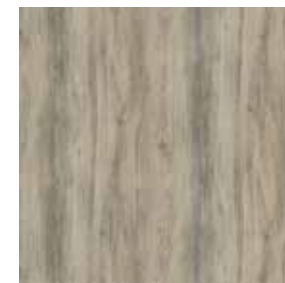

Fremantle

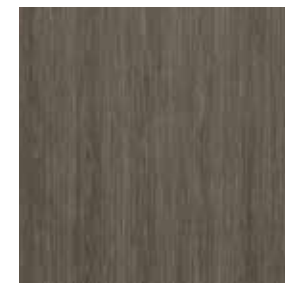

Grey Gum



Hamilton



Hollywood



Hoop Pine



Jarrahdale



Kew Walnut



Norwood



Oakbeach



Oakwood

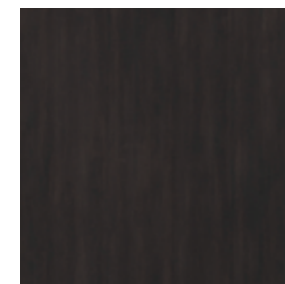

Ravenswood



Scarborough

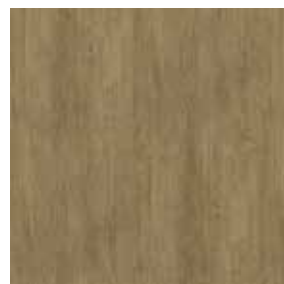

Sherwood

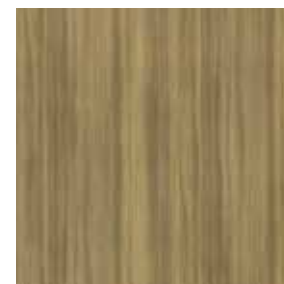

Tablelands



The Oaks



Toorak



Windslow Ash



Windsor

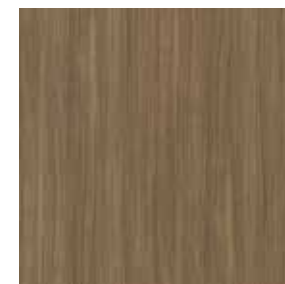

Yarra Walnut

Colorways



Peppercorn



Lipstick Red

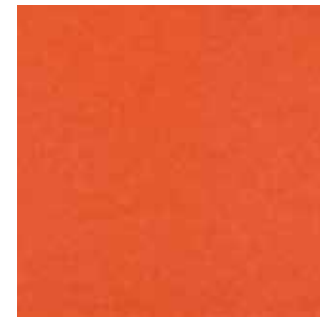

Carrot



Peach



Butter



Popcorn



Pistachio



Thistle



Oregano

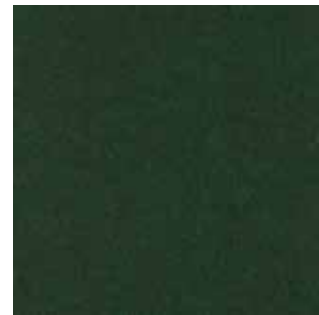

Kale



Wasabi



Denim



Peacock



Azur

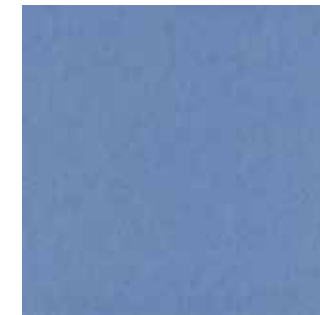

Marine



Periwinkle



Lilac



Iris

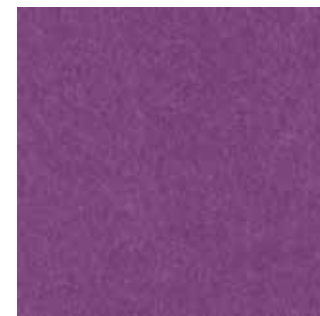

Berry



Midnight

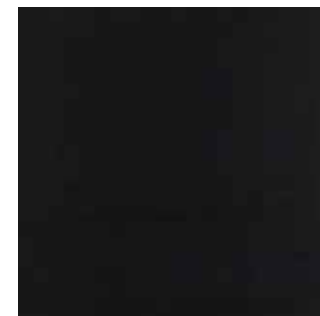

Piano Black



Charcoal



Slate

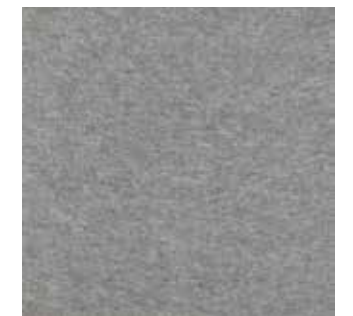

Grey



Metal



Platinum



White

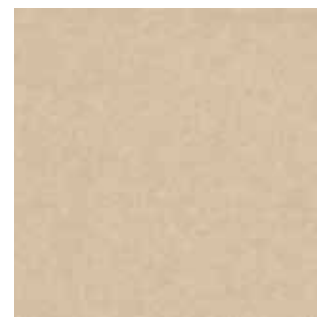

Ivory



Pearl

Mounting Methods

Constructive Adhesive

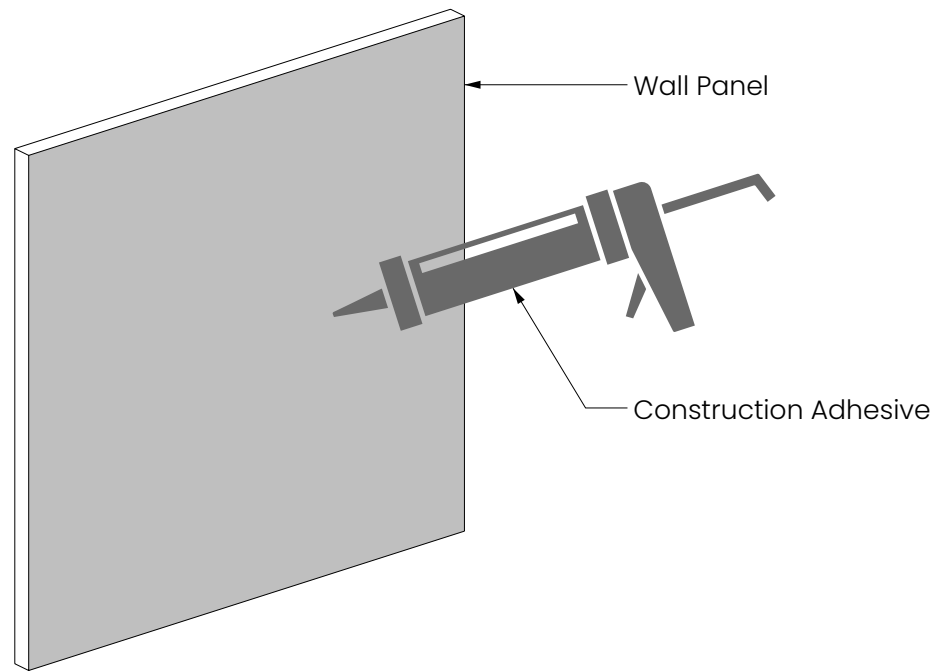

Pot Magnet Install

Wall Pot Magnet Install Metal Plate

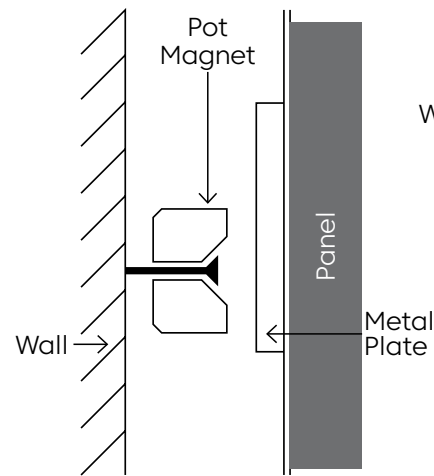

Wall Pot Magnet Install L Plate + Metal Plate

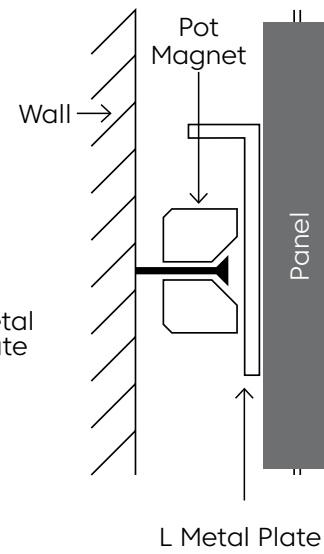

L Plate Wall + Metal Plate Configuration

○ L Metal Plate × Metal Plate



Slat Profile & Panel Size – Horizontal

FilaSorb 12 + 13mm Woodgrain Finish

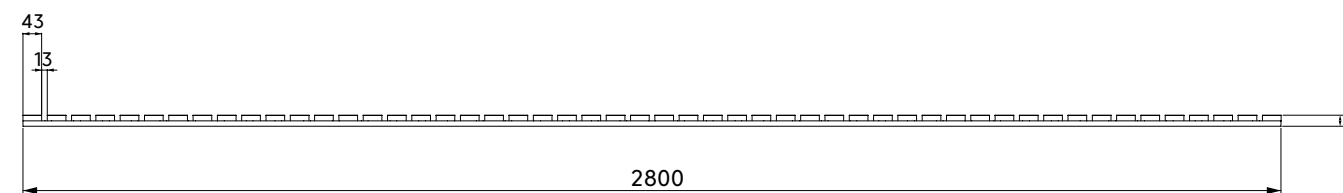
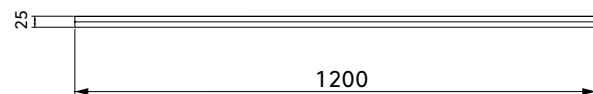
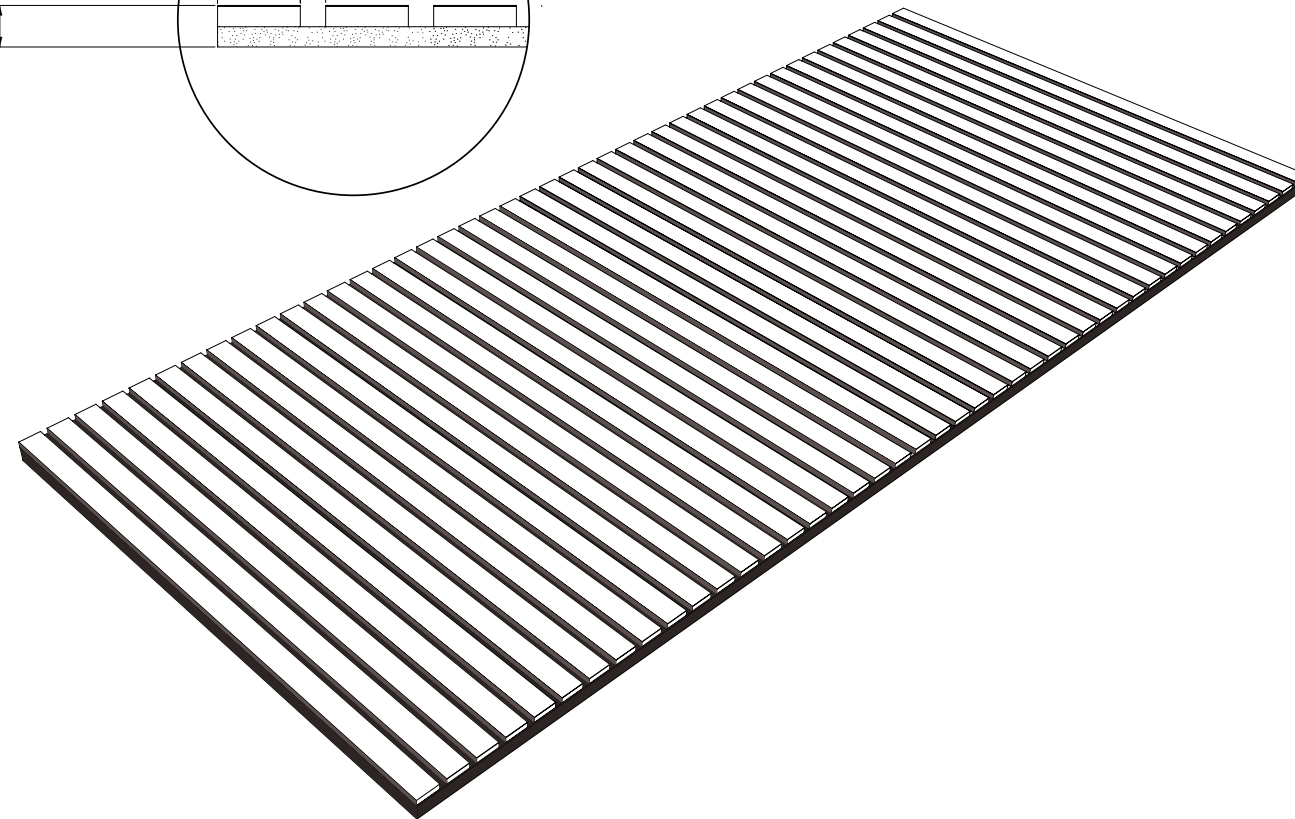
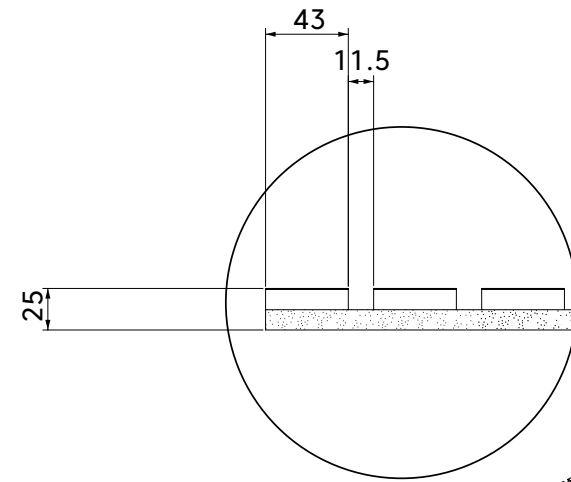
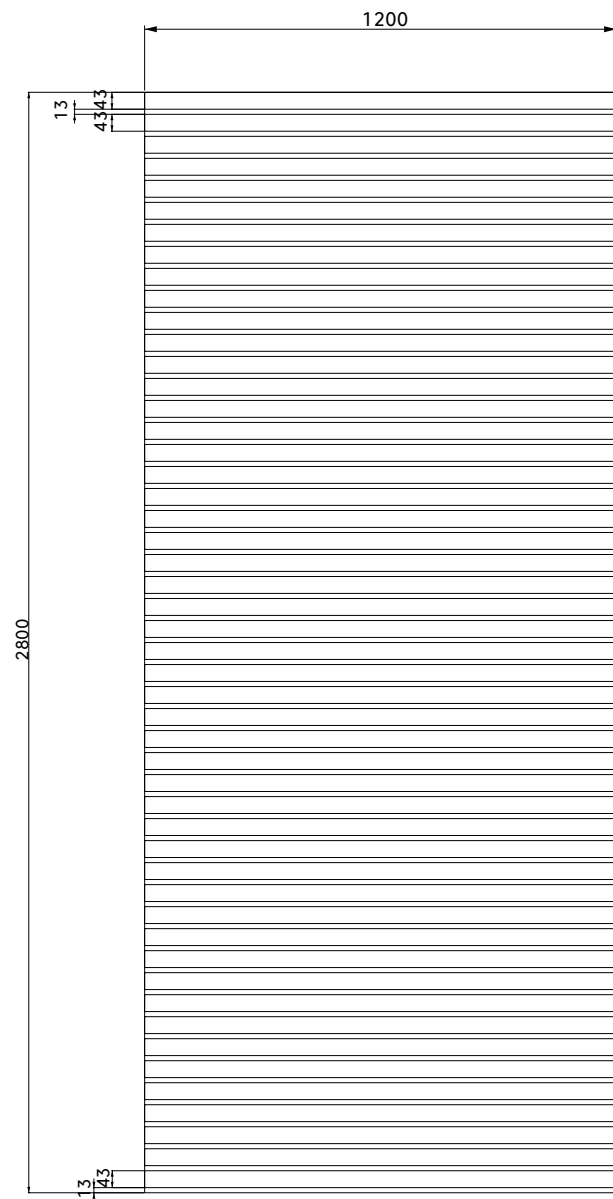

Slat Profile & Panel Size – Vertical

FilaSorb 12 + 13mm Woodgrain Finish

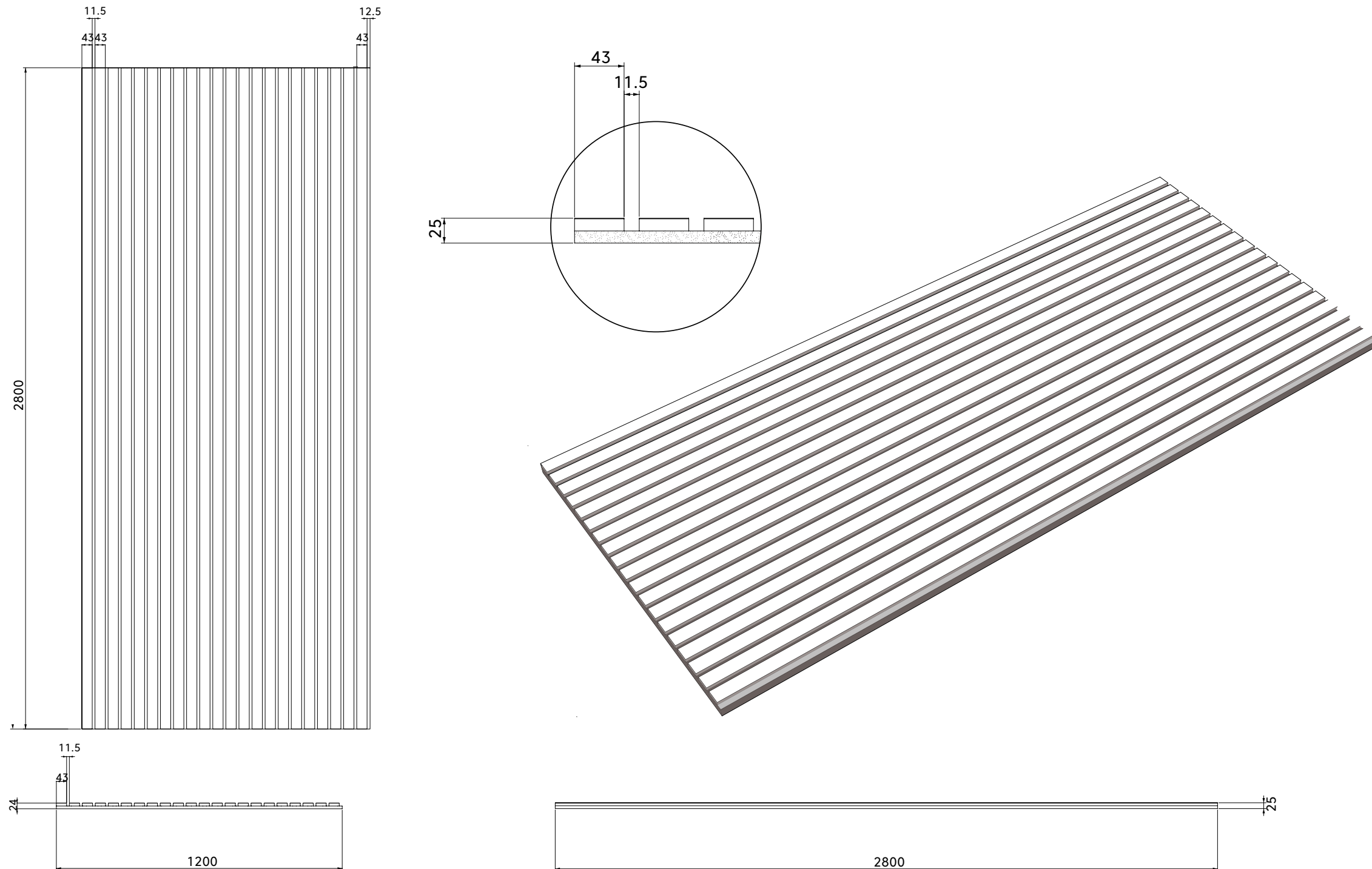

Slat Profile & Panel Size – Horizontal

FilaSorb 12 + 4mm Woodgrain Finish

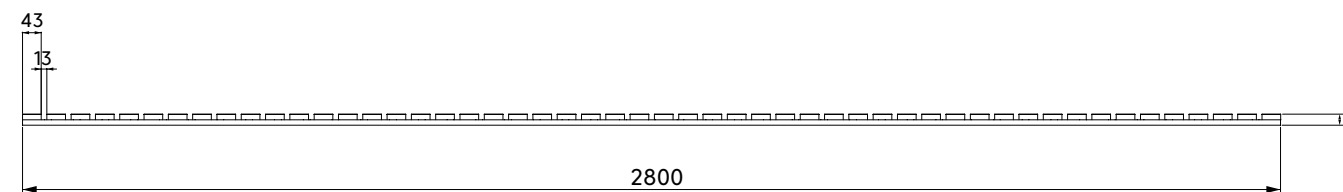
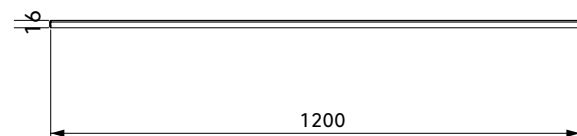
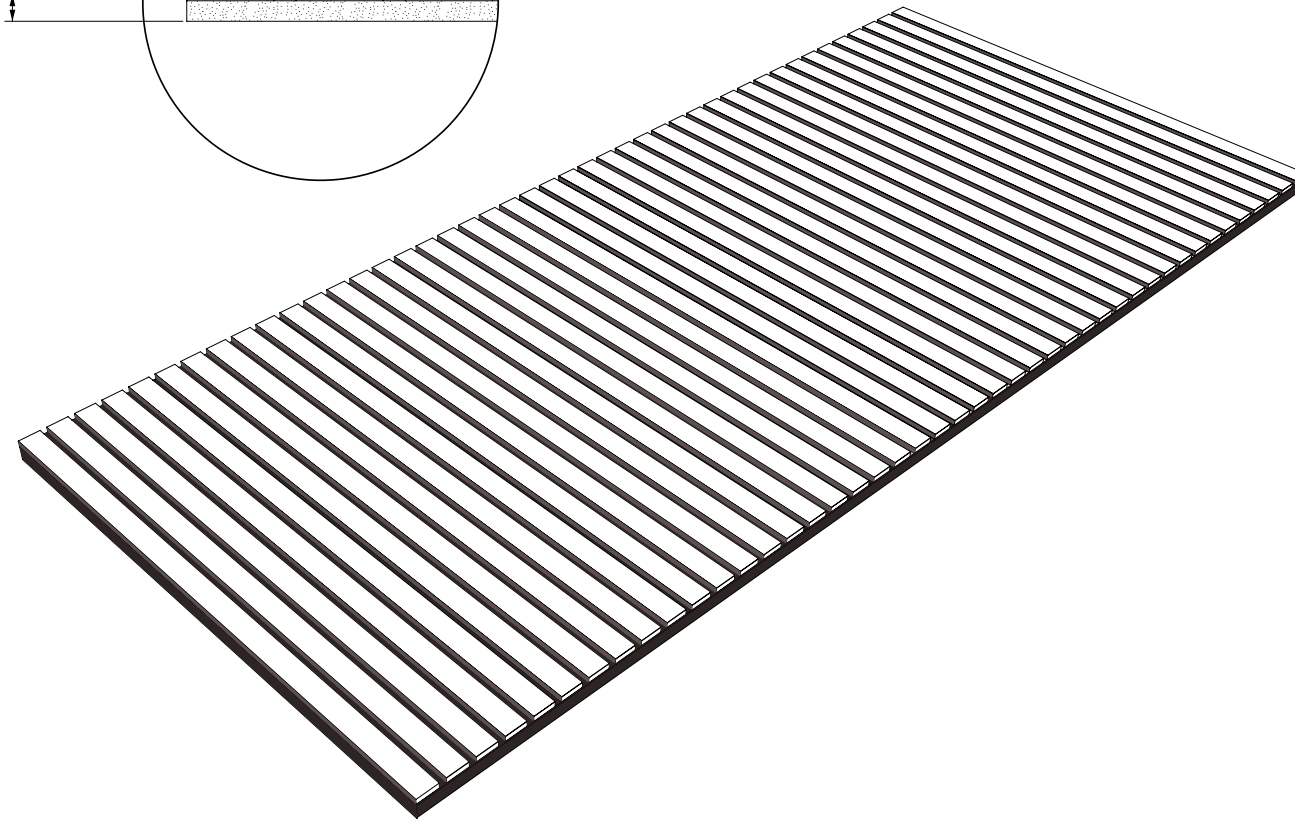
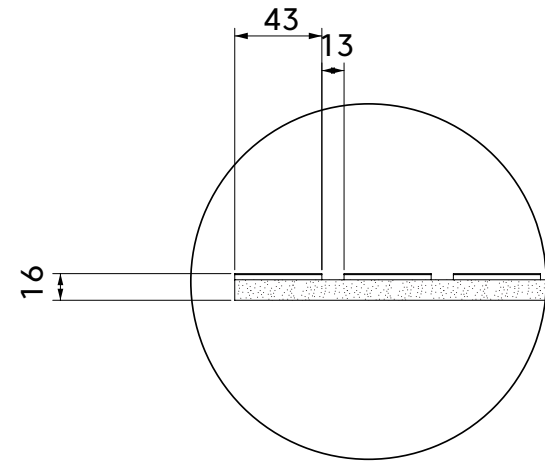
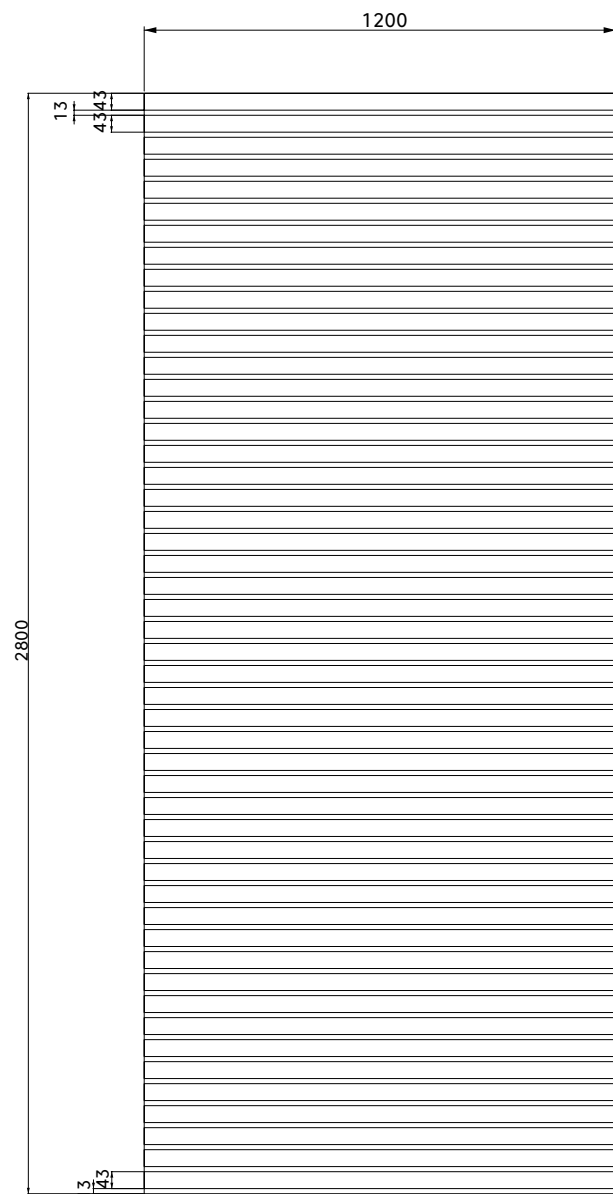

Slat Profile & Panel Size – Vertical

FilaSorb 12 + 4mm Woodgrain Finish

